



HD402T PRESSURE TRANSMITTERS

- Sensor with high accuracy and stability
- Measurement of pressures relative to the atmosphere or differential pressures
- Dual analogue output: current and voltage
- Versions with or without LCD display

Applications

- Control of air conditioning and ventilation
- Control of filters
- Monitoring of clean rooms
- Pneumatic controls
- Respirators
- Vaporizers



Description

The series of transmitters HD402T... is suitable for measuring relative pressure with respect to atmosphere or differential pressure in the range from 50 Pa to 200 kPa.

These transmitters use a silicon piezoresistive sensor with high accuracy and temperature compensation, which has excellent linearity, repeatability and stability over the time.

The output signal of the sensor is converted into a standard analog output to be chosen between voltage 0...10 V or current 0...20 mA or 4...20 mA. The current output signal can be transmitted over long distances with high immunity to interference (the maximum distance depends on the load and the section of the connection cables, but distances of several hundred meters are commonly reached).

The tool offers a wide range of configurations. Besides the full scale (f.s.), different measuring units can be chosen for each instrument, and it is also possible to set the unipolar (0 ... +f.s.) or bipolar (-f.s. ... +f.s.) measuring range.

The configuration can be made through a series of dip switches mounted on the circuit board or by connecting the serial port of the transmitter to the PC.

Thanks to the particular sensor used, the transmitters are insensitive to orientation and position. Moreover, the high stability of the sensor over the time and in comparison to the changes in temperature allows to eliminate the operations of maintenance typically required to compensate for the aging and the deviation of the sensor zero.

The option "display" (L) is available, in this case the values of pressure are displayed on a 4-digit display under the unit of measure set by the user.

The transmitters are supplied ready for use and factory calibrated in 3 points.

As an alternative to the configuration of the transmitter by means of the dip switches, a serial output is available for the configuration via PC.

Power supply with 24Vac alternating voltage or 16...40 Vdc direct voltage.

Technical specifications

Sensor	Piezoresistive, High stability
Measuring range	from 0...50 Pa to 0...200 kPa both relative and differential (please refer to table 1)
Resolution	Please refer to table 2
Accuracy @ 25 °C	± 1.5% f.s. nominal for HD402T1 ± 0.75% f.s. nominal for HD402T2 ± 1% f.s. nominal for HD402T3, HD402T4 and HD402T5
Accuracy @ 0...50 °C	± 3% f.s. nominal for HD402T1 ± 1% f.s. nominal for HD402T2, HD402T3, HD402T4 and HD402T5
Long term stability (1000 h) @ 25 °C	± 0.5% f.s. nominal for HD402T1 and HD402T2 ± 0.35% f.s. nominal for HD402T3 ± 0.25% f.s. nominal for HD402T4 and HD402T5
Output signal	0...10 Vdc $R_L > 10\text{ k}\Omega$ and 0...20 or 4...20 mA $R_L < 500\ \Omega$
Response time	0.25 seconds for the analog outputs 0.5 seconds for the display updating
Overpressure limit	50 kPa for the models with f.s. up to 10 kPa 200 kPa for the model with f.s. 100 kPa 400 kPa for the model with f.s. 200 kPa
Compatible media	Only air and non-aggressive dry gases
Power supply	24 Vac $\pm 10\%$ or 16...40 Vdc
Absorption	< 1 W @ 24 Vdc
Pressure connection	\varnothing 5 mm hose
Electrical connections	Screw terminal block, max 1.5 mm ² , PG9 fairlead for the input cable
Operating conditions	-10...+60 °C / 0...95% RH
Storage temperature	-20...+70 °C
Housing dimensions	80 x 84 x 44 mm
Protection degree	IP67

TAB. 1: full scale values and units of measurement

Model	Pa	kPa	mbar	mmH ₂ O	inchH ₂ O	mmHg	PSI
HD402T1	50/100/250	---	0,5/1/2,5	5/10/25	0,2/0,4/1	---	---
HD402T2	250/500/1000	---	2,5/5/10	25/50/100	1/2/4	---	---
HD402T3	---	2,5/5/10	25/50/100	---	---	10/25/50	0,4/0,75/1,5
HD402T4	---	25/50/100	250/500/1000	---	---	100/250/500	4/7,5/15
HD402T5	---	50/100/200	500/1000/2000	---	---	250/500/1000	10/15/30

TAB. 2: resolution

Modello	Pa	kPa	mbar	mmH ₂ O	inchH ₂ O	mmHg	PSI
HD402T1	0.1	---	0.001	0.01	0.001	---	---
HD402T2	1	---	0.01	0.1	0.01	---	---
HD402T3	---	0.01	0.1	---	---	0.01	0.001
HD402T4	---	0.1	1	---	---	0.1	0.01
HD402T5	---	0.1	1	---	---	1	0.01

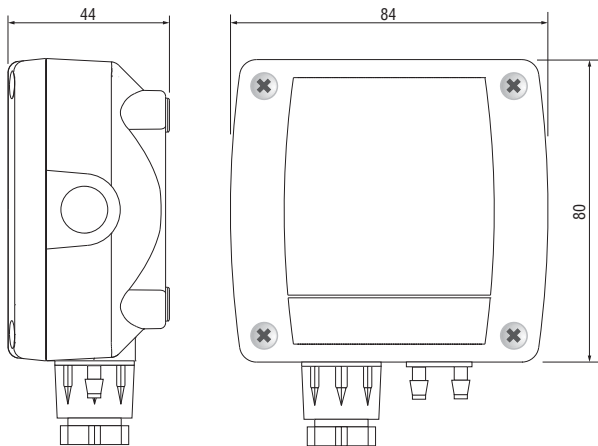

Fig. 1: dimensions (mm)

Installation

In any model the sensor and the electronics are housed in a rugged plastic case with IP67 protection degree. By opening the lid, 3 mm diameter holes are available so to allow securing the base of the transmitter directly to a panel or to the wall.

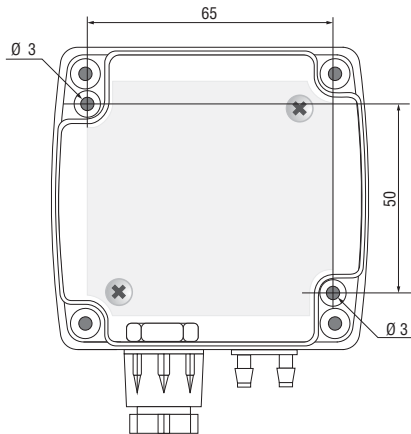

Fig. 2: fixing holes (dimensions in mm)

The transmitter can be mounted in any position, but typically it is secured on a vertical wall with the pressure taps facedown. The deviation of the zero due to the mounting position can be corrected by using CAL ZERO. The procedure for the manual calibration of the zero is the following:
 make sure that the transmitter is powered at least for 1 hour;
 disconnect both the tubes from the pressure + and - inputs;
 press CAL ZERO until the red LED starts flashing;
 when the red LED turns off, the zeroing procedure is completed and you can reconnect the tube to the pressure connections.
 It is recommended to follow the auto-zero procedure at least once a year under normal operating conditions.

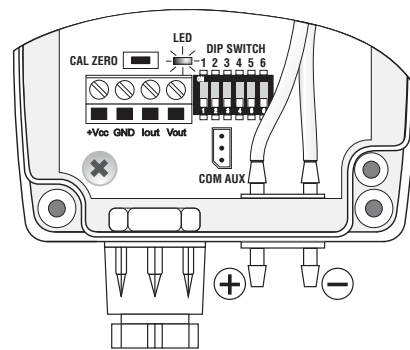

Fig. 3: CAL ZERO key and configuration dip switch

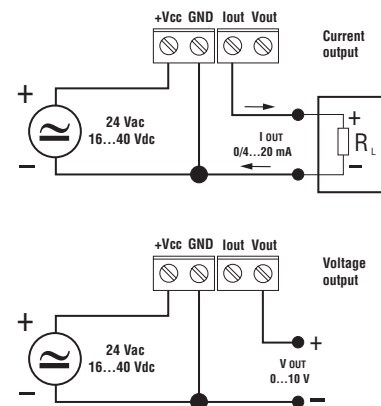

Fig. 4: electrical connections

Configuration

Setting the configuration mode: the transmitter can be configured by using the dip switches on the circuit board or via the serial communication port COM AUX. The choice of the configuration mode is done with the dip switch 1:

- Dip switch 1 = ON → the configuration set through the dip switches 2...6 is used
- Dip switch 1 = OFF → the configuration set via serial port is used

Configuration by dip switch

The configuration of the dip switches is used by the transmitter only if the dip switch 1 is ON.
 The dip switches 2 and 3 select the low, intermediate or high measuring range.
 The dip switches 4 and 5 select one of the four available units in the model.
 The dip switch 6 sets the unipolar (0... + f.s.) or bipolar (-f.s... + f.s.) measuring range.
 A dip switch is OFF when placed down, towards the serial connector. Instead, it is ON if placed up, towards the DIP SW sign.
 The following tables report the measuring range, for each model, corresponding to the analog outputs according to dip switch positions.

TAB. 3: measuring ranges for outputs of the model HD402T1

Dip switch number										
6	2	3	4		5		4		5	
			OFF	OFF	ON	OFF	OFF	ON	ON	ON
			Pa		mmH ₂ O		inchH ₂ O		mbar	
OFF	OFF	ON	0...50.0 Pa		0...5.00 mmH ₂ O		0...0.200 inchH ₂ O		0...0.500 mbar	
	ON	OFF	0...100.0 Pa		0...10.00 mmH ₂ O		0...0.400 inchH ₂ O		0...1.000 mbar	
	OFF	OFF	0...250.0 Pa		0...25.00 mmH ₂ O		0...1.000 inchH ₂ O		0...2.500 mbar	
	ON	ON	0...250.0 Pa		0...25.00 mmH ₂ O		0...1.000 inchH ₂ O		0...2.500 mbar	
ON	OFF	ON	-50.0...+50.0 Pa		-5.00...+5.00 mmH ₂ O		-0.200...+0.200 inchH ₂ O		-0.500...+0.500 mbar	
	ON	OFF	-100.0...+100.0 Pa		-10.00...+10.00 mmH ₂ O		-0.400...+0.400 inchH ₂ O		-1.000...+1.000 mbar	
	OFF	OFF	-250.0...+250.0 Pa		-25.00...+25.00 mmH ₂ O		-1.000...+1.000 inchH ₂ O		-2.500...+2.500 mbar	
	ON	ON	-250.0...+250.0 Pa		-25.00...+25.00 mmH ₂ O		-1.000...+1.000 inchH ₂ O		-2.500...+2.500 mbar	

TAB. 4: measuring ranges for outputs of the model HD402T2

Dip switch number										
6	2	3	4		5		4		5	
			OFF	OFF	ON	OFF	OFF	ON	ON	ON
			Pa		mmH ₂ O		inchH ₂ O		mbar	
OFF	OFF	ON	0...250 Pa		0...25.0 mmH ₂ O		0...1.00 inchH ₂ O		0...2.50 mbar	
	ON	OFF	0...500 Pa		0...50.0 mmH ₂ O		0...2.00 inchH ₂ O		0...5.00 mbar	
	OFF	OFF	0...1000 Pa		0...100.0 mmH ₂ O		0...4.00 inchH ₂ O		0...10.00 mbar	
	ON	ON	0...1000 Pa		0...100.0 mmH ₂ O		0...4.00 inchH ₂ O		0...10.00 mbar	
ON	OFF	ON	-250...+250 Pa		-25.0...+25.0 mmH ₂ O		-1.00...+1.00 inchH ₂ O		-2.50...+2.50 mbar	
	ON	OFF	-500...+500 Pa		-50.0...+50.0 mmH ₂ O		-2.00...+2.00 inchH ₂ O		-5.00...+5.00 mbar	
	OFF	OFF	-1000...+1000 Pa		-100.0...+100.0 mmH ₂ O		-4.00...+4.00 inchH ₂ O		-10.00...+10.00 mbar	
	ON	ON	-1000...+1000 Pa		-100.0...+100.0 mmH ₂ O		-4.00...+4.00 inchH ₂ O		-10.00...+10.00 mbar	

TAB. 5: measuring ranges for outputs of the model HD402T3

Dip switch number										
6	2	3	4		5		4		5	
			OFF	OFF	ON	OFF	OFF	ON	ON	ON
			kPa		mmHg		PSI		mbar	
OFF	OFF	ON	0...2.50 kPa		0...10.00 mmHg		0...0.400 PSI		0...25.0 mbar	
	ON	OFF	0...5.00 kPa		0...25.00 mmHg		0...0.750 PSI		0...50.0 mbar	
	OFF	OFF	0...10.00 kPa		0...50.00 mmHg		0...1.500 PSI		0...100.0 mbar	
	ON	ON	0...10.00 kPa		0...50.00 mmHg		0...1.500 PSI		0...100.0 mbar	
ON	OFF	ON	-2.50...+2.50 kPa		-10.00...+10.00 mmHg		-0.400...+0.400 PSI		-25.0...+25.0 mbar	
	ON	OFF	-5.00...+5.00 kPa		-25.00...+25.00 mmHg		-0.750...+0.750 PSI		-50.0...+50.0 mbar	
	OFF	OFF	-10.00...+10.00 kPa		-50.00...+50.00 mmHg		-1.500...+1.500 PSI		-100.0...+100.0 mbar	
	ON	ON	-10.00...+10.00 kPa		-50.00...+50.00 mmHg		-1.500...+1.500 PSI		-100.0...+100.0 mbar	

TAB. 6: measuring ranges for outputs of the model HD402T4

Dip switch number										
6	2	3	4		5		4		5	
			OFF	OFF	ON	OFF	OFF	ON	ON	ON
			kPa		mmHg		PSI		mbar	
OFF	OFF	ON	0...25.0 kPa		0...100.0 mmHg		0...4.00 PSI		0...250 mbar	
	ON	OFF	0...50.0 kPa		0...250.0 mmHg		0...7.50 PSI		0...500 mbar	
	OFF	OFF	0...100.0 kPa		0...500.0 mmHg		0...15.00 PSI		0...1000 mbar	
	ON	ON	0...100.0 kPa		0...500.0 mmHg		0...15.00 PSI		0...1000 mbar	
ON	OFF	ON	-25.0...+25.0 kPa		-100.0...+100.0 mmHg		-4.00...+4.00 PSI		-250...+250 mbar	
	ON	OFF	-50.0...+50.0 kPa		-250.0...+250.0 mmHg		-7.50...+7.50 PSI		-500...+500 mbar	
	OFF	OFF	-100.0...+100.0 kPa		-500.0...+500.0 mmHg		-15.00...+15.00 PSI		-1000...+1000 mbar	
	ON	ON	-100.0...+100.0 kPa		-500.0...+500.0 mmHg		-15.00...+15.00 PSI		-1000...+1000 mbar	

TAB. 7: measuring ranges for outputs of the model HD402T5

Dip switch number										
6	2	3	4		5		4		5	
			OFF	OFF	ON	OFF	OFF	ON	ON	ON
			kPa		mmHg		PSI		mbar	
OFF	OFF	ON	0...50.0 kPa		0...250 mmHg		0...10.00 PSI		0...500 mbar	
	ON	OFF	0...100.0 kPa		0...500 mmHg		0...15.00 PSI		0...1000 mbar	
	OFF	OFF	0...200.0 kPa		0...1000 mmHg		0...30.00 PSI		0...2000 mbar	
	ON	ON	0...200.0 kPa		0...1000 mmHg		0...30.00 PSI		0...2000 mbar	
ON	OFF	ON	-50.0...+50.0 kPa		-250...+250 mmHg		-10.00...+10.00 PSI		-500...+500 mbar	
	ON	OFF	-100.0...+100.0 kPa		-500...+500 mmHg		-15.00...+15.00 PSI		-1000...+1000 mbar	
	OFF	OFF	-200.0...+200.0 kPa		-1000...+1000 mmHg		-30.00...+30.00 PSI		-2000...+2000 mbar	
	ON	ON	-200.0...+200.0 kPa		-1000...+1000 mmHg		-30.00...+30.00 PSI		-2000...+2000 mbar	

Configuration via the serial port COM AUX

The configuration set with the serial communication is used by the transmitter only if the dip switch 1 is OFF.

In order to modify the settings, please proceed as follows:

Connect the serial COM AUX output of the transmitter to the RS232 port (via the RS27 cable) or USB (via the cable CP27) of the PC. If you use the CP27 cable, install the USB drivers on your PC.

On the PC, launch a program for serial communication (e.g. Hyperterminal), set the baud rate to 115200 and the communication parameters to 8N1.

Send the commands given in Table 9 to set the measurement range corresponding to the analog outputs.

TAB. 9: comandi seriali di configurazione

Command	Response	Description
Kn	&	Set the unit of measurement of index n HD402T1 & HD402T2 HD402T3 & HD402T4 & HD402T5 n=0 → Pa n=0 → kPa n=1 → mmH ₂ O n=1 → mmHg n=2 → inchH ₂ O n=2 → PSI n=3 → mbar n=3 → mbar
Rn	&	Sets the measuring range of index n n=0 → high range (e.g. 250 Pa / 25 mmH ₂ O / 1 "H ₂ O / 2,5 mbar in HD402T1) n=1 → intermediate range (e.g. 100 Pa / 10 mmH ₂ O / 0,4 "H ₂ O / 1 mbar in HD402T1) n=2 → low range (e.g. 50 Pa / 5 mmH ₂ O / 0,2 "H ₂ O / 0,5 mbar in HD402T1)
PU	&	Set the unipolar measuring range (0...+f.s.)
PB	&	Set the bipolar measuring range (-f.s....+f.s.)
U0	&	Set the interval 0...20 mA for the analog current output
U1	&	Set the interval 4...20 mA for the analog current output

In order to read the settings of the transmitter, send the commands described in Table 10.

TAB. 10: serial commands to read the configuration

Comando	Risposta	Descrizione
G0	See the example below	It reads the current configuration of the transmitter. If the dip switch 1 is OFF, it returns the configuration set via the serial port. If the dip switch 1 is set to ON, it returns the configuration set by dip switch
GF	See the example below	It reads the configuration set by the serial port
GS	See the example below	It reads the configuration set by the dip switch

The commands for reading the configuration return a string consisting of:

- model
- full scale value set for the analog outputs
- polarity of the measuring range (U=unipolar, B=bipolar)
- range of the analog output current (0=0...20mA, 4=4...20 mA)

for example: the string "HD402T2 5.00mbar B40" indicates that the transmitter model is HD402T2, the full scale set for the analog outputs is 5.00 mbar, the measuring range is bipolar (-5.00...+5.00 mbar) and the analog current output type is 4...20 mA. The last character of the string (0 in the example) is a confidential code.

Display

Models with suffix L are equipped with a 4-digit LCD display. In models with LCD option, the measuring range shown on the display is always bipolar (-f.s....+f.s.) and related to the maximum full scale available in the model (the setting of the measuring range only affects the behavior of the analog outputs). The measure on the display is updated twice a second.

Error messages:

- Undr → it appears if the measured value is less than the minimum measurable value
- OvEr → it appears if the measured value exceeds the maximum measurable value
- CAL Error → it appears at the end of the zero calibration if the maximum off-set value possible to be corrected is exceeded.

Purchasing codes

HD402T...: Pressure relative to the atmosphere or differential pressure transmitters. For dry air and non-aggressive gases. Barbed connection diam. 5 mm for hose. Analogue output at choice between voltage 0...10 V or current 0...20 mA or 4...20 mA. Operating temperature -10...+60 °C. Power supply 16...40 Vdc or 24 Vac.

HD402T - **L**

L = with LCD display

Nominal full scale (f.s.):	
1	= 250 Pa / 25 mmH ₂ O / 1 inchH ₂ O / 2,5 mbar
2	= 1000 Pa / 100 mmH ₂ O / 4 inchH ₂ O / 10 mbar
3	= 10 kPa / 50 mmHg / 1,5 PSI / 100 mbar
4	= 100 kPa / 500 mmHg / 15 PSI / 1000 mbar
5	= 200 kPa / 1000 mmHg / 30 PSI / 2000 mbar

Accessories

- Included:
 N°1 piece of silicone tubing Ø3.2/Ø6.4, length 2m
 N°2 plastic fittings HD434T.5

Upon request:

- HD3719:** Air inlet for square or cylindrical channel.
- HD3721:** Air inlet for cylindrical channel, made of plastic.
- RS27:** RS232 null-modem serial connection cable with SubD 9-pin connector on the PC side and 3-pole connector on the side of the instrument.
- CP27:** Serial connection cable with USB connector on the PC side and 3-pole connector on the side of the instrument. The cable has a built-in USB/RS232 converter and it connects the instrument directly to the USB port of the PC.

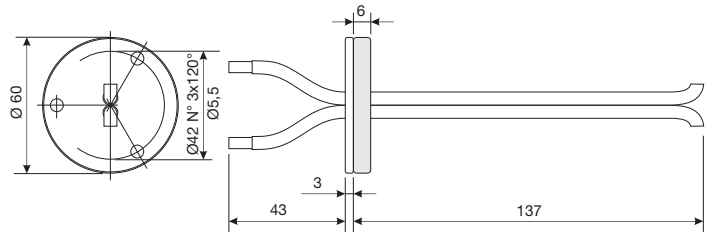

Fig. 5: channel probe AP3719

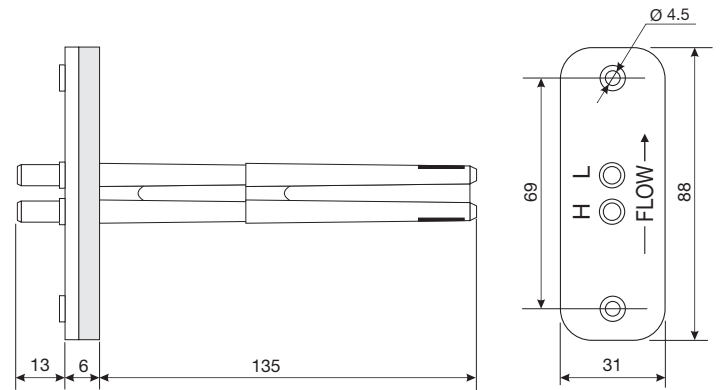

Fig. 6: channel probe AP3721

Example of connection with the indicator controller HD9022

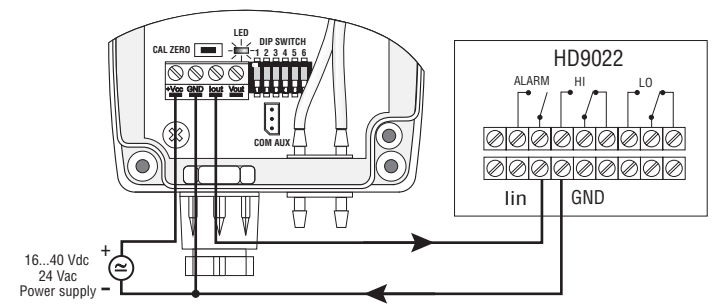

Fig. 7: current output 0...20 or 4...20 mA

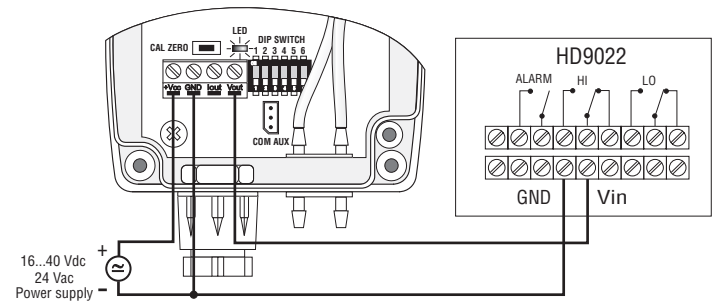

Fig. 8: voltage output 0...10 Vdc