

Economy Types



- Encoder for universal installation by means of front/back panel mounting
- High efficiency by means of ball bearing
- Small torque
- Application e.g.:
 - FHP motors
 - laboratory equipment
 - labelling machines
 - plotters
 - length measuring machines

NUMBER OF PULSES

5 / 10 / 20 / 25 / 28 / 32 / 50 / 60 / 72 / 100 / 128 / 144 / 200 / 250 / 256 / 288 / 300 / 360 / 400 / 500 / 512 / 600 / 720 / 900 / 1,000 / 1,024
 Other numbers of pulses available on request

TECHNICAL DATA mechanical

Shaft diameter	6 mm
Absolute max. shaft load	radial 30 N (6.5 lbs), axial 15 N (3.3 lbs)
Absolute maximum speed	max. 10,000 RPM
Torque	≤ 0.2 Ncm
Protection class (EN 60529)	Housing IP 50, bearings IP 40
Operating temperature	-10 ... +60 °C
Storage temperature	-25 ... +85 °C
Vibration proof	100 m/s ² (10 ... 2000 Hz)
Shock resistance	1000 m/s ² (6 ms)
Type of connection	1.5 m cable, radial ¹⁾
Housing	glassfibre reinforced plastic
Flange	Q = square flange
Weight	60 g approx.
Bearing life	1 x 10 ¹⁰ revolutions (typ.) at 35% of full rated shaft load 1 x 10 ⁹ revolutions (typ.) at 75% of full rated shaft load 1 x 10 ⁸ revolutions (typ.) at 100% of full rated shaft load For example 30,000 h at 6,000 RPM with a 2 lb radial load

¹⁾ Other cable length on request

TECHNICAL DATA electrical

General design	as per DIN VDE 0160, protection class III, contamination level 2, overvoltage class II
Supply voltage (SELV)	with push-pull (D): 5VDC ± 10% with push-pull (K): 5VDC ¹⁾ ± 10% oder 10 ... 30VDC ¹⁾
Power consumption	40 mA (5 VDC), 60 mA (10 VDC), 30 mA (24 VDC)
Standard-Output versions ²⁾	push-pull (K, D): A, B, N, \overline{A} alarm

¹⁾ Pole protection

²⁾ Output description and technical data see section "Output"

Incremental Shaft Encoders Type RI 38

Economy Types

DIMENSIONED DRAWING

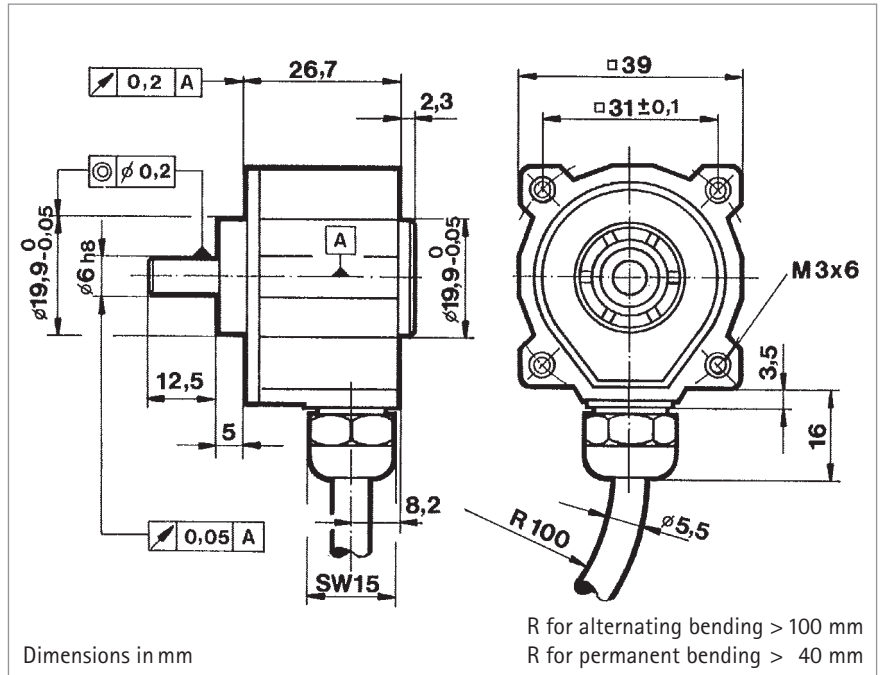

CONNECTION DIAGRAM

Description (push-pull)	Lead Ø mm ²	Colour
5 VDC/10-30 VDC	0,5	red
Channel A	0,14	white
Channel B	0,14	green
Channel N	0,14	yellow
GND	0,5	black
Alarm	0,14	yellow/black

ORDERING DATA

0 Standard	Supply voltage A 5 VDC E 10 ... 30 VDC ¹⁾	Type of flange Q square flange	Shaft diameter 1 6 mm
RI 38 - 0		Q · 1	1
Number of pulses 5 ... 1024	Protection class 1 IP 40	Output K push-pull ²⁾ short circuit proof D push-pull 5 V, ± 30 mA	Type of connection B cable radial
			B

¹⁾ only with output K

²⁾ ± 10 mA at 5 V, ± 30 mA at 10 ... 30 V