

TECHNICAL DATASHEET

Incremental Encoder RI 64



- Through hollow shaft and hubshaft up to 16 mm
- Robust design
- High shock and vibrations resistance
- PPR: Up to 5000
- Electrically insulated shaft: protection from shaft currents
- High temperature range: -40°C ... + 100°C
- Protection class IP67: also for through hollow shaft
- Applications: Feedback for asynchronous motors, industrial applications



NUMBER OF PULSES

360 / 1000 / **1024** / 2000 / **2048** / 3600 / **4096** / 5000

**TECHNICAL DATA
mechanical**

Housing diameter	63 mm
Mounting depth	54"
Shaft diameter	10 mm / 12 mm / 14 mm / 15 mm / 16 mm (Hubshaft) 12 mm / 14 mm / 15 mm / 16 mm (Through hollow shaft)
Flange (Mounting of housing)	Tether
Mounting of shaft	Front clamping ring, Rear clamping ring
Protection class shaft input (EN 60529)	IP64 or IP67
Axial endplay of mounting shaft (hubshaft)	± 0.8 mm
Radial runout of mating shaft (hubshaft)	± 0.2 mm
Max. speed	Hub shaft: max. 12 000 rpm Through hollow shaft: max. 6000 rpm
Vibration resistance (DIN EN 60068-2-6)	100 m/s ²
Shock resistance (DIN EN 60068-2-27)	1000 m/s ²
Operating temperature	-40 °C ... +100 °C
Material shaft	Aluminum, ceramic coating
Material housing	Aluminum
Weight	approx. 180 g
Connection	Cable, axial or radial Cable with M23 connector

**TECHNICAL DATA
electrical**

Supply voltage	DC 5 V ±10 % DC 5 - 26 V
Max. pulse frequency	300 kHz
Index pulse width (N)	180° electrical
Number of pulses	1 ... 5000
Pulse shape	Square wave

TECHNICAL DATASHEET

Incremental Encoder RI 64

ELECTRICAL CONNECTIONS

M23 connector (Conin), 12 pole / cable

Colour	PIN	Signal
Red	12	DC 5/ 5 - 26 V
Black	10	GND
Blue	5	A
Green	8	B
Violet	3	N
Blue/ Black	6	\bar{A}
Green/ Black	1	\bar{B}
Violet/ Black	4	\bar{Z}
Screen	Screen	Screen

DIMENSIONED DRAWINGS

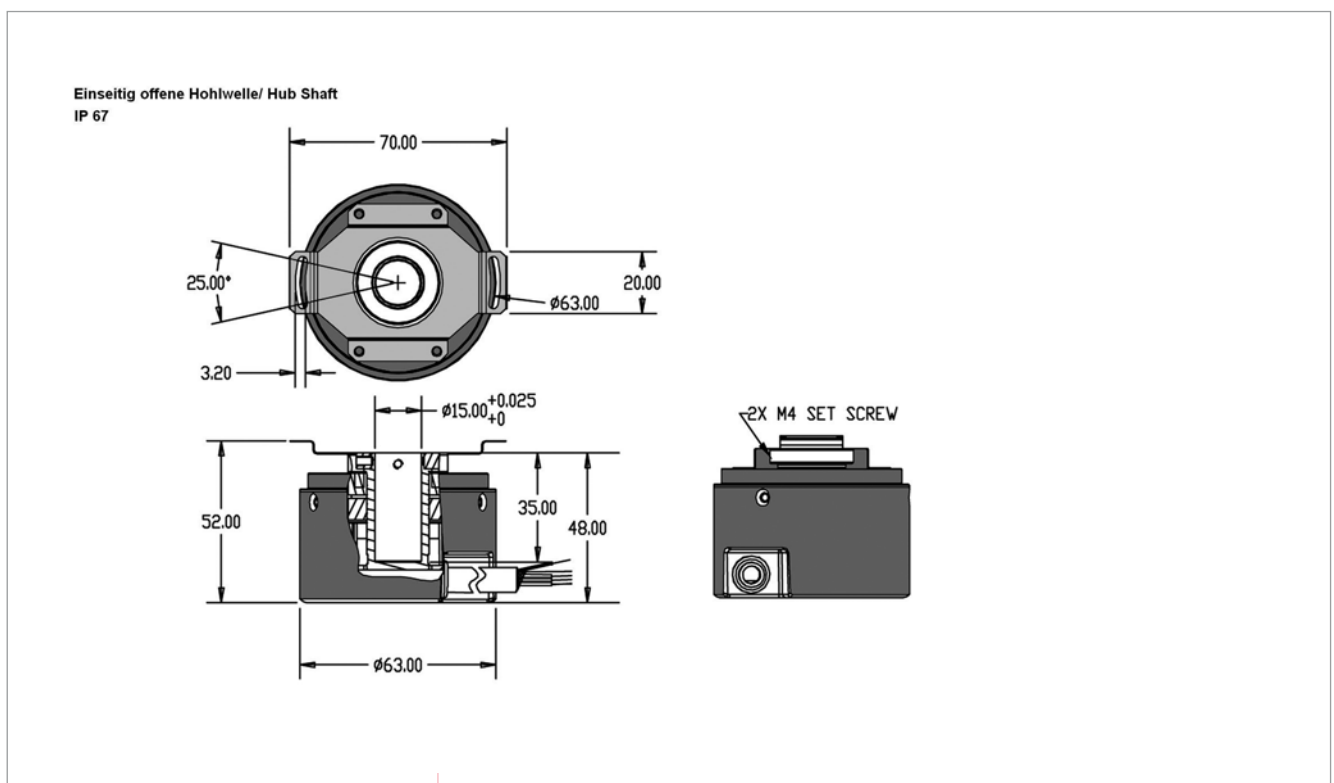

TECHNICAL DATASHEET

Incremental Encoder RI 64

DIMENSIONED DRAWINGS (continued)

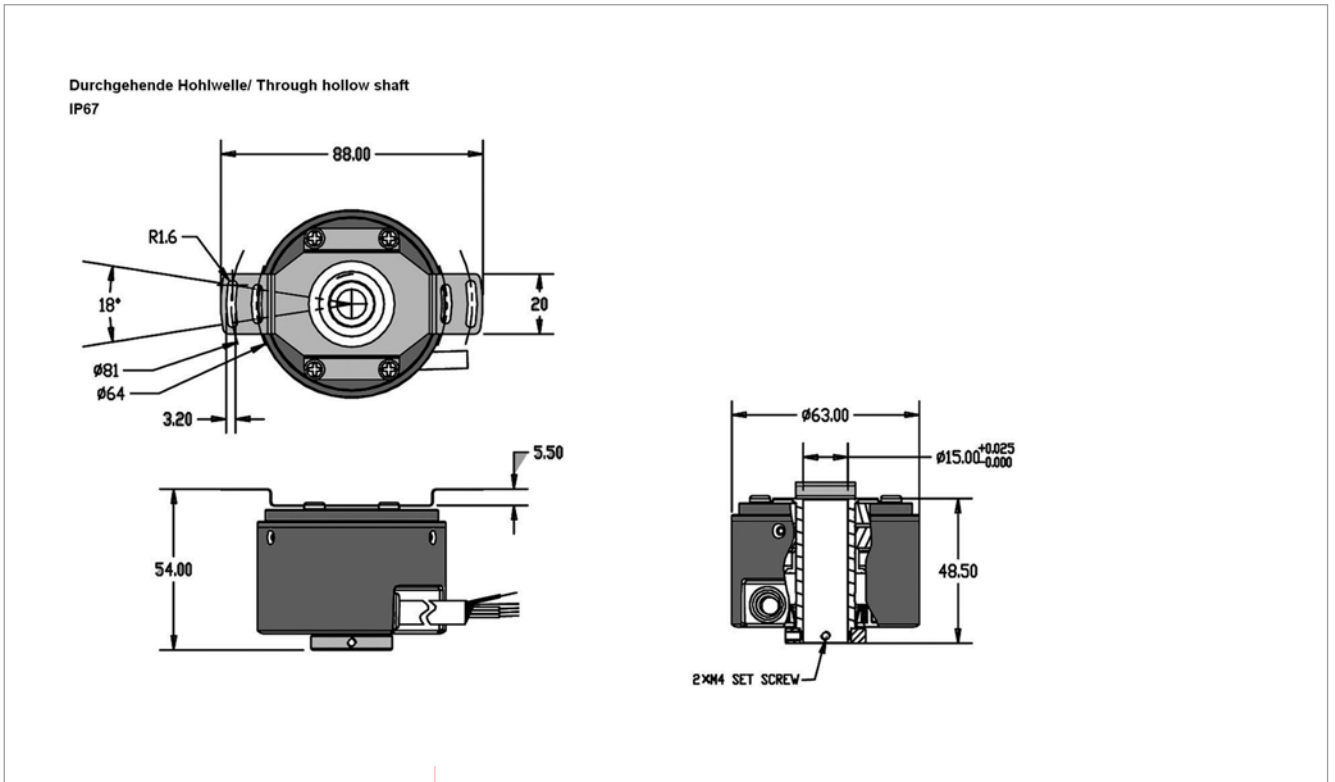

OUTPUT WAVEFORMS

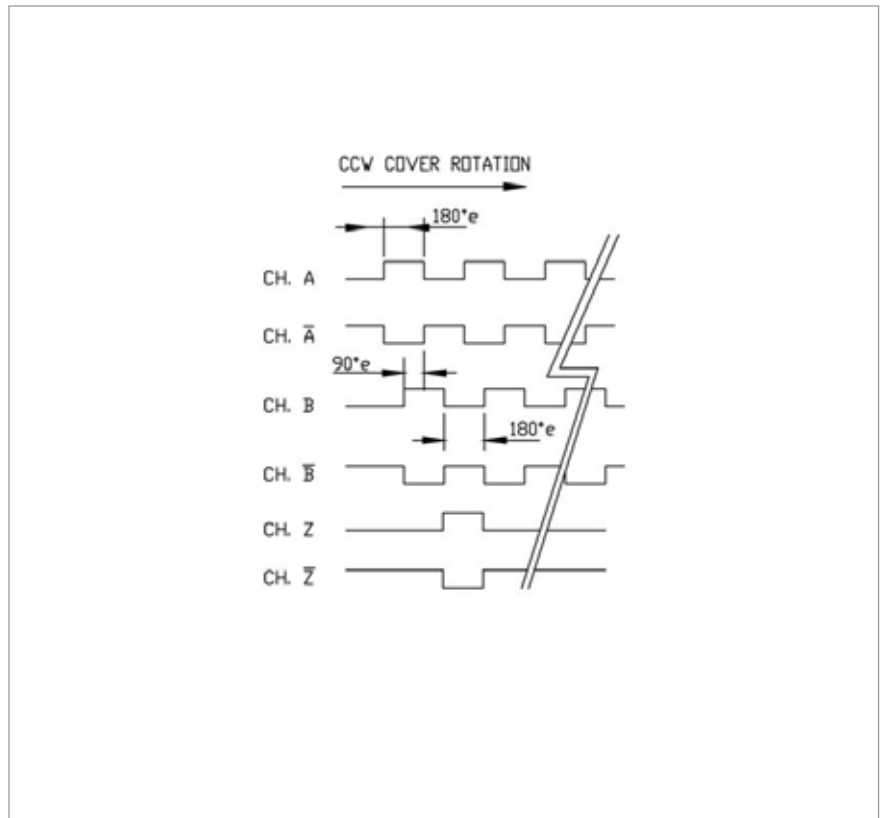

TECHNICAL DATASHEET

Incremental Encoder RI 64

ORDERING INFORMATION

	Number of pulses	Supply voltage ^{1,2}	Spring tether	Protection	Shaft	Shaft Ø	Output	Connection ³
<input type="checkbox"/>	<input type="checkbox"/>	<input type="checkbox"/>	<input type="checkbox"/>	<input type="checkbox"/>	<input type="checkbox"/>	<input type="checkbox"/>	<input type="checkbox"/>	<input type="checkbox"/>
	0360 1000 1024 2000 2048 3600 4096 5000	A DC 5 V B DC 5 - 30 V	O Without tether V 63 W 81/64	4 IP64 7 IP67	H Clamping shaft with clamping ring rear F hub shaft with clamping ring front	2 10 mm 7 12 mm 9 14 mm D 15 mm G 16 mm	I Push-pull complementary T RS422	B PVC cable, radial B-I Cable with M23 connector, cw B-D Cable with M23-connector, ccw

¹ DC 5 V only with output T

² DC 5 - 26 V only with output I

³ Standard cable length for variant with connector 1.5 m. For other cable length use chart below.

ORDERING INFORMATION

Selection of cable length

Versions with cable outlet (connection A, B, E or F) are available with various lengths of cable. To order your desired cable length, please add the respective code to the end of your ordering code. For variants with connector on cable end please add cable length code in between. Further cable lengths on request.

Code	Cable length
without code	1.5 m
-D0	3 m
-F0	5 m
-K0	10 m
-P0	15 m
-U0	20 m
-V0	25 m

Example:

Cable 3 m length: ... B - D0

Cable mit 3 m length and M23 connector, cw: ... B - D0 - I