

TEMPERATURE SENSOR

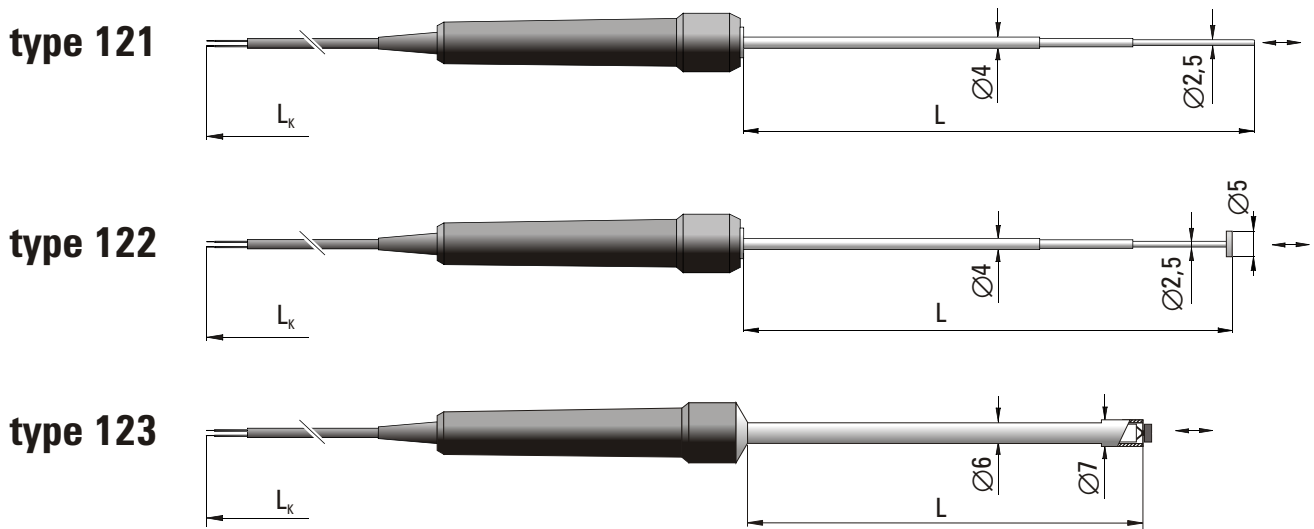

SPECIFICATION

Application	temperature measurement of surfaces
Temperature range	-40°C... +800°C (TP-121), (TP-122) -40°C... +400°C (TP-123)
Measuring element	thermocouple NiCr-NiAl (K) ⁽¹⁾
Class of processing element	2
Measuring junction	grounded ⁽²⁾
Sensor length L	100, 150, 200, 250, 300 mm ⁽²⁾
Length of compensation cable L _k	spiral 1,5 m ⁽²⁾
Sheath material	steel 1.4541
Handle and cable operating temperature	-20°C... +80°C
Additional accessories	plug type MT-K (for use with hand held thermometers) ⁽²⁾

⁽¹⁾ Other thermocouples on demand

⁽²⁾ Other parameters according to customer requirements

ORDERING CODE



Sensor type **121, 122, 123**

Sensor length L = **100, 150, 200, 250** or **300** mm⁽²⁾

Additional accessories: plug type **MT-K**

Example for order:

TP-121-300-MT-K sensor based on sheathed thermocouple NiCr-NiAl (K), length L = 300 mm and length of compensation cable L_k = 1,5 m with plug type MT-K.