

Pyranometers

For the Accurate Measurement of Solar Irradiance

Installed around the world by national networks

Specifications to ISO 9060:1990 and IEC 60904 standards

Widely used within World Meteorological Organisation scientific programmes

The broadest range of pyranometers and accessories available

Introduction

Solar radiation drives almost every dynamic process on the Earth's surface and above, from ocean current circulation to the weather, and life itself. Precise long-term measurements of the radiation budget at the surface are fundamental to understanding the Earth's climate system. Rising fossil fuel costs and the need to reduce Carbon footprints has produced a rapid growth in the market for 'green' energy, in which the fastest growing sector is solar power.

Scientists, researchers and commercial companies in renewable energy, climatology, weather, agriculture, water resources and environment all require accurate and reliable measurements of solar radiation. The measurement is made by pyranometers, which are radiometers designed for measuring the total (global) irradiance on a plane surface resulting from radiant fluxes in the wavelength range from 300 nanometers (nm), or less, to 3000 nm.

Kipp & Zonen has been manufacturing pyranometers for over 85 years. We produce models at all price and performance points, up to the very best available. All comply with the

requirements of ISO 9060:1990 and are fully traceable to the World Radiometric Reference (WRR) in Davos, Switzerland, where Kipp & Zonen instruments form part of the World Standard Group.

Our top level pyranometers have exceptional levelling accuracy, built-in temperature sensors and a test certificate with individually measured directional and temperature responses. These important features ensure the highest accuracy measurements. Kipp & Zonen pyranometers are designed for a long operating life with simple maintenance and a wide range of accessories is available.

Applications

Kipp & Zonen pyranometers have been developed to be suitable for use in all environments, from the Antarctic to deserts. They are installed around the world for meteorology, hydrology, climate research, solar energy, environmental and materials testing, greenhouse control, building automation and many other applications.

The CMP10 is specially designed for applications where regular visits and maintenance is difficult. A dedicated brochure is available for the CM 4, for use in climate chambers up to 150°C.

CMP 3 is smaller and lighter than the other CMP Series pyranometers. It has a robust 4 mm thick glass dome to protect the thermopile from external influences. The small size and sealed construction make this instrument the ideal choice for horticulture, monitoring solar energy installations, industrial applications, and it can be used underwater. A screw-in mounting rod is available for easy installation.

CMP 6 has a similar detector to CMP 3, but has improved performance due to the increased thermal mass and the double glass dome construction. It is recommended for cost-effective, good quality, measurements in meteorological and hydrological networks and agriculture.

CMP10 is the secondary standard pyranometer with the best price-quality-performance ratio on the market. With the same specifications and detector as CMP 11, CMP10 extends this quality to applications where maintenance is difficult and/or forms a major part of the cost of ownership.

The CMP10 has internal desiccant that lasts for at least 10 years. This minimizes maintenance significantly. The interval for dome cleaning can be extended, and the quality of measurements maximized, by adding the CVF4 ventilation unit.

Kipp & Zonen provides every CMP10 with a 5-year warranty as standard. This warranty applies provided that the CMP10 is used only under atmospheric conditions, that the housing is not opened and that the Kipp & Zonen cable and connector is correctly fitted. The internal desiccant is changed with every factory re-calibration.

CMP 11 uses a temperature compensated detector. It is a step up in performance from CMP 6 and particularly suitable for upgrading meteorological networks. The faster response time meets the requirements for solar energy research and development applications. CMP 11 is also ideal for use in sun tracker based solar monitoring stations.

Choice of Pyranometer

To achieve the required spectral and directional characteristics CMP Series pyranometers use thermopile detectors and glass or quartz domes. All models have built-in bubble levels and adjustable levelling feet. The waterproof connectors have gold-plated contacts and are fitted with 10 m of high quality signal cable as standard. The instruments do not require power and are supplied with comprehensive calibration certificates.

The most appropriate model for an application largely depends on the desired accuracy and performance.





CMP 21 is similar to CMP 11 but has individually optimised temperature compensation. A standard thermistor sensor is fitted to monitor the housing temperature. Each instrument is supplied with its own temperature and directional (cosine) response data. It is the choice for scientific use and in top level solar radiation monitoring networks such as the Baseline Surface Radiation Network (BSRN) of the World Meteorological Organisation.

CMP 22 has all the features of CMP 21 but uses very high quality quartz domes for a wider spectral range, improved directional response, and reduced thermal offsets. Because of the high optical quality of these domes the directional error is reduced below 0.5% up to 80° solar zenith angle. Kipp & Zonen is confident that CMP 22 is the best pyranometer currently available.

Building a System

The system capabilities of Kipp & Zonen pyranometers can be extended with our wide range of compatible products and accessories. Please refer to our website www.kippzonen.com for more information on the following products.

Albedometer

To calculate Albedo the incoming global radiation is measured by a pyranometer facing upward and the radiation reflected by the ground is measured by a pyranometer facing downward. CMA 6 and CMA 11 are integrated Albedometer versions of CMP 6 and CMP 11. Details can be found in our dedicated Albedometer brochure.

Ventilation Unit

CVF4 ventilation unit is designed for use with all CMP Series pyranometers (CMP 3 fits but ventilation is less effective). Ventilation helps to keep the dome clean and reduces infrared thermal offsets by stabilization of the dome temperature. The two levels of heating can be used to remove raindrops, dew, frost and snow.

Sun Tracker

SOLYS 2 and 2AP sun trackers are all-weather reliable instruments used to accurately point a pyr heliometer at the sun for direct radiation measurements. When fitted with an optional shading assembly and a pyranometer they measure diffuse radiation with no need for periodic manual adjustments. Adding a second pyranometer for the global radiation makes a high quality solar monitoring station.



Shadow Ring

The combination of a pyranometer and a CM 121 shadow ring offers a simple solution for measuring diffuse radiation from the sky. The ring only requires simple adjustment every few days to ensure that the shadow covers the pyranometer dome completely as the sun moves across the sky.

Amplification

Pyranometers have low output signals in the mV range. AMPBOX converts this to the industrial standard 4 to 20 mA current loop signal and provides a defined output range in W/m². Amplification is advised for noisy environments, use with data acquisition equipment with high-level inputs, and for very long cables (> 100 m). For pyranometers with amplified analog and digital outputs, see our SMP series.

Data loggers

Kipp & Zonen has a range of high performance data logging and display products for use with CMP series pyranometers and our other solar radiometers.

Mounting

Kipp & Zonen offers mounting fixtures for horizontal, tilted and down looking pyranometers. CMF 1 is a small round plate with integral rod for mounting upward and/or downward facing pyranometers. CMB 1 is a mounting bracket for mounting a 12-20 mm rod to a mast, 22-60 mm pole or wall. The adjustable tilt CMP mounting kit allows for tilted mounting of the pyranometer with a 0° to 90° graduated scale for the zenith angle.

Glare Screen Kit

A downward facing pyranometer should not see any radiation coming from the hemisphere above or from the first 5° below the horizon. To prevent this, a glare screen kit is available for use with all CMP series pyranometers (except the CMP 3).

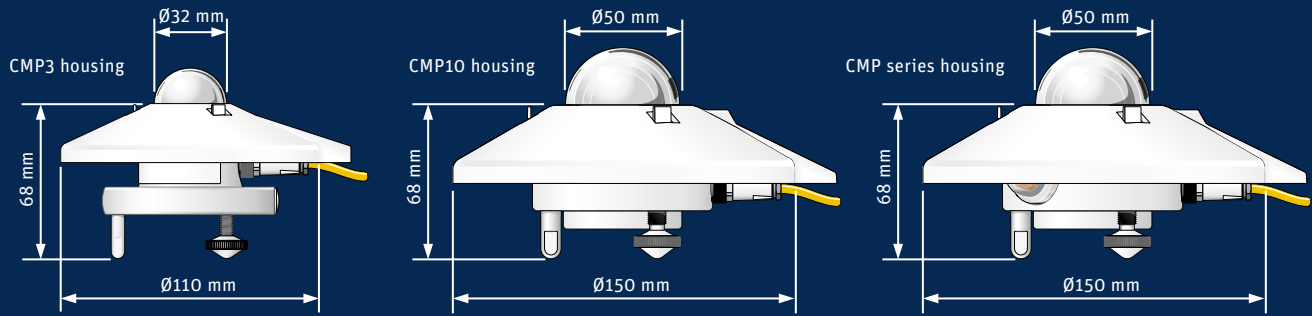

Specifications	CMP 3	CMP 6	CMP10 & CMP 11	CMP 21	CMP 22
Classification to ISO 9060:1990	Second Class	First Class	Secondary Standard	Secondary Standard	Secondary Standard
Spectral range (50% points)	300 to 2800 nm	285 to 2800 nm	285 to 2800 nm	285 to 2800 nm	200 to 3600 nm
Sensitivity	5 to 20 $\mu\text{V}/\text{W}/\text{m}^2$	5 to 20 $\mu\text{V}/\text{W}/\text{m}^2$	7 to 14 $\mu\text{V}/\text{W}/\text{m}^2$	7 to 14 $\mu\text{V}/\text{W}/\text{m}^2$	7 to 14 $\mu\text{V}/\text{W}/\text{m}^2$
Impedance	20 to 200 Ω	20 to 200 Ω	10 to 100 Ω	10 to 100 Ω	10 to 100 Ω
Expected output range (0 to 1500 W/m^2)	0 to 30 mV	0 to 30 mV	0 to 20 mV	0 to 20 mV	0 to 20 mV
Maximum operational irradiance	2000 W/m^2	2000 W/m^2	4000 W/m^2	4000 W/m^2	4000 W/m^2
Response time (63%)	< 6 s	< 6 s	< 1.7 s	< 1.7 s	< 1.7 s
Response time (95%)	< 18 s	< 18 s	< 5 s	< 5 s	< 5 s
Zero offsets					
(a) thermal radiation (at 200 W/m^2)	< 15 W/m^2	< 12 W/m^2	< 7 W/m^2	< 7 W/m^2	< 3 W/m^2
(b) temperature change (5 K/h)	< 5 W/m^2	< 4 W/m^2	< 2 W/m^2	< 2 W/m^2	< 1 W/m^2
Non-stability (change/year)	< 1%	< 1%	< 0.5%	< 0.5%	< 0.5%
Non-linearity (100 to 1000 W/m^2)	< 1.5%	< 1%	< 0.2%	< 0.2%	< 0.2%
Directional response (up to 80° with 1000 W/m^2 beam)	< 20 W/m^2	< 20 W/m^2	< 10 W/m^2	< 10 W/m^2	< 5 W/m^2
Spectral selectivity (350 to 1500 nm)	< 3%	< 3%	< 3%	< 3%	< 3%
Temperature response	< 5% (-10°C to +40°C)	< 4% (-10°C to +40°C)	< 1% (-10°C to +40°C)	< 1% (-20°C to +50°C)	< 0.5% (-20°C to +50°C)
Tilt response (0° to 90° at 1000 W/m^2)	< 1%	< 1%	< 0.2%	< 0.2%	< 0.2%
Field of view	180°	180°	180°	180°	180°
Accuracy of bubble level	< 0.2°	< 0.1°	< 0.1°	< 0.1°	< 0.1°
Temperature sensor output				10 K Thermistor (optional Pt-100)	10 K Thermistor (optional Pt-100)
Detector type	Thermopile	Thermopile	Thermopile	Thermopile	Thermopile
Operational temperature range	-40°C to +80°C	-40°C to +80°C	-40°C to +80°C	-40°C to +80°C	-40°C to +80°C
Storage temperature range	-40°C to +80°C	-40°C to +80°C	-40°C to +80°C	-40°C to +80°C	-40°C to +80°C
Humidity range	0 to 100% non-condensing	0 to 100% non-condensing	0 to 100% non-condensing	0 to 100% non-condensing	0 to 100% non-condensing
Ingress Protection (IP) rating	67	67	67	67	67
Recommended applications	Economical solution for routine measurements in weather stations, field testing	Good quality measurements for hydrology networks, greenhouse climate control	Meteorological networks, PV panel and thermal collector testing, materials testing	Meteorological networks, reference measurements in extreme climates, polar or arid	Scientific research requiring the highest level of measurement accuracy and reliability

Note: The performance specifications quoted are worst-case and/or maximum values

Standard 10 k Thermistor or optional Pt-100 temperature sensor with CMP 21 and CMP 22

Individual directional response and temperature dependence test data with CMP 21 and CMP 22



Go to www.kippzonen.com for your local distributor

HEAD OFFICE

Kipp & Zonen B.V.
 Delftechpark 36, 2628 XH Delft
 P.O. Box 507, 2600 AM Delft
 The Netherlands
 T: +31 (0) 15 2755 210
 F: +31 (0) 15 2620 351
 info@kippzonen.com

Kipp & Zonen B.V. reserve the right to alter specifications of the equipment described in this documentation without prior notice