

# Series CCT

**Signal Integrators with isolation  
for Vdc and mA signal integration**



**CCT-55V**  
**CCT-55I**

**input in Vdc, output in frequency**  
**input in mA, output in frequency**

*IDEAL SOLUTION to convert a wide range of analogue signals (process, temperatures, current, frequencies...) to standard 10Vdc or 20mA process signals, for further retransmission to a remote data acquisition system or PLC's. The galvanic isolation offered by the CCT instruments between the signal circuit and the remote equipment, reduces to a minimum any eventual problem related to ground loops between different circuits.*

# Models CCT-55V and CCT-55I

## Integrators for Vdc and mA, with frequency output

Integrator for analogue signals in Vdc and mAdc with frequency output. This frequency is proportional to the analogue input signal. Selection of input and output ranges with internal jumpers and potentiometers. Galvanic isolation between input, output and power circuits.



### Order Reference

| CCT | Model      | Power               | Input         | Output                  |
|-----|------------|---------------------|---------------|-------------------------|
| -   | <b>55V</b> | <b>0</b>            | <b>0/100V</b> | <b>0/1000 imp./sec.</b> |
|     | - 55V      | -0 (230 Vac)        | 0/650 Vdc     | 0/5000 imp./hour        |
|     | - 55I      | -1 (115 Vac)        | 0/100V        | 0/1000 imp./sec.        |
|     |            | -2 (24 Vac)         | 0/10V         | ...                     |
|     |            | -3 (48 Vac)         | 0/50mA        |                         |
|     |            | -6 (24Vdc isolated) | 4/20mA        |                         |
|     |            |                     | ...           |                         |

### Technical Data

|                          |                                                                       |
|--------------------------|-----------------------------------------------------------------------|
| Accuracy                 | Class <0.2                                                            |
| Ripple                   | <0,5 %                                                                |
| Temperature coefficient  | <0,015 %/ °C                                                          |
| Pass band                | 1.5 Hz (-3 dB a 3Hz)                                                  |
| Response time            | <250 mSec.                                                            |
| Vexc (55I model)         | 24Vdc (@25mA max.)                                                    |
| Output in pulses/sec.    | from 0 to 10.000                                                      |
| Output in pulses/hour    | from 0 to 8.790                                                       |
| Output in voltage pulses | 24Vdc (@20mA max.)                                                    |
| Output in current pulses | 100mA (needs external power for the current loop, at 24Vdc)           |
| Isolation                | 2 KVeFF / 50Hz / 1 min (tested at 4 KVeFF)                            |
| Isolated circuits        | input / output / power                                                |
| Weight                   | 270 gr.                                                               |
| Wire section             | 4mm2 maximum                                                          |
| Housing IP protection    | IP40                                                                  |
| Terminals IP protection  | IP20                                                                  |
| Housing material         | polycarbonate, light grey RAL 7032, UL 94 V-1                         |
| Mounting                 | standard DIN rail (DIN46277, DIN EN 50022) (35 x 7,5mm) (1,38 x 0,3") |
| Terminals                | Polycarbonate, UL 94 V-2                                              |
| Consumption              | <1,5 VA                                                               |
| Storage temperature      | -30 to +80 °C                                                         |
| Working temperature      | -10 to +60 °C                                                         |

### Access to internal circuits

With a flat screwdriver, force the front cover and walls towards **A** and **B**, until fixations '3' are free. Take the instrument from points '2', and extract it pulling towards **C**, until the internal circuits appear. The internal circuits have the following names:

- ME .- Signal Input Module
- MS .- Signal Output Module
- MA .- Power Module
- MP .- Personalized Module

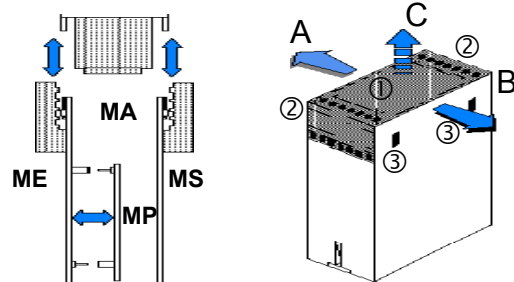

### Power options

The CCT converters allow different power modules in AC and DC. The instrument does not have internal protection fuse. Following is a recommendation on value and type of fuse for each power module available.

| Ref. | Power            | Fuse Recommended |
|------|------------------|------------------|
| «0»  | 230 Vac 50/60 Hz | 50 mA Time Lag   |
| «1»  | 115 Vac 50/60 Hz | 100 mA Time Lag  |
| «2»  | 24 Vac 50/60 Hz  | 300 mA Time Lag  |
| «3»  | 48 Vac 50/60 Hz  | 150 mA Time Lag  |
| «6»  | 24 Vdc           | 300 mA Fast Fuse |

# CCT-55V

## Integrator for DC Voltage up to 650 Vdc

Integrator for voltage DC signals. Internal jumper selection for 5 different ranges of measure, ranging from 0/100 mVdc up to 0/650 Vdc. The frequency output is proportional to the analogue input value.

### INPUT RANGE SELECTION

Configure the desired Vdc input range by selecting the appropriate jumpers on «MP» module, as shown on the table below:

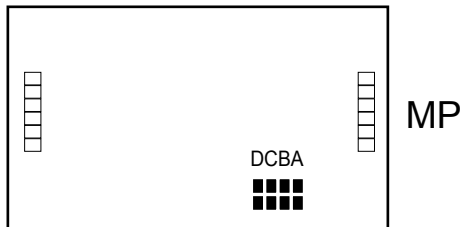

| RANGE   | JUMPERS «MP» | OVERLOAD | Zin      | RANGE MINIMUM |
|---------|--------------|----------|----------|---------------|
| 650 Vdc | B            | 1000Vdc  | 1 MOhm   | 100V          |
| 100 Vdc | D            | 1000Vdc  | 1 MOhm   | 10V           |
| 10 Vdc  | ---          | 1000V dc | 1 MOhm   | 1V            |
| 1 Vdc   | ---          | 75Vdc    | 100 KOhm | 100mV         |
| 100mVdc | A            | 25Vdc    | 100 KOhm | 10mV          |

# CCT-55I

## Integrator for DC Current up to 50 mAdc

Integrator for DC current signals. Internal jumper selection for 4 different ranges of measure, ranging from 0/5 mAdc up to 0/50 mAdc. The frequency output is proportional to the analogue input value.

### INPUT RANGE SELECTION

Configure the desired mAdc input range by selecting the appropriate jumpers on «MP» module, as shown on the table below:

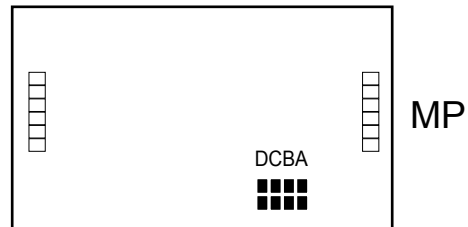

| RANGE     | JUMPERS «MP» / «ME» | OVERLOAD | Zin    | RANGE MINIMUM |
|-----------|---------------------|----------|--------|---------------|
| 0/50 mAdc | D / ---             | 100 mAdc | 20 Ohm | 5 mAdc        |
| 4/20 mAdc | D / A,C             |          |        |               |
| 0/20 mAdc | D / C               |          |        |               |
| 0/5 mAdc  | A,D / ---           | 100 mAdc | 20 Ohm | 0,5 mAdc      |

### CONNECTIONS

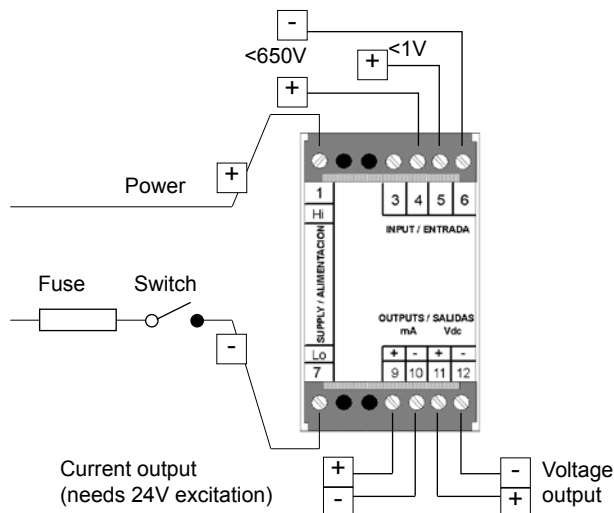

### CONNECTIONS

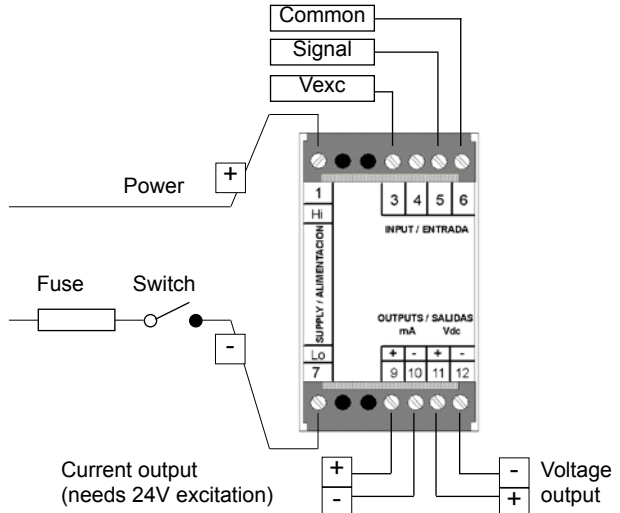

### Output signal module (MS55)

Configure the desired frequency range and the pulse width by selecting the appropriate jumpers on «MS55» module, as shown on the table below:

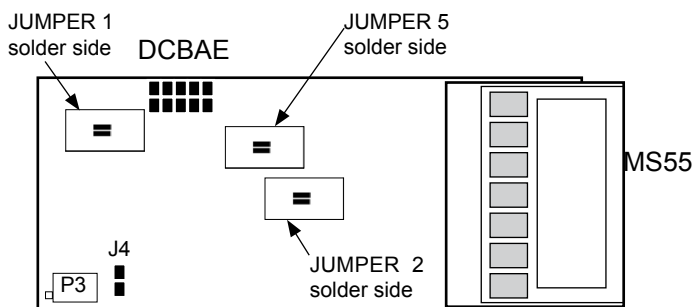

| Pulses / hour                                           | Close jumpers on MS55 | Pulses/sec.                      | Close jumpers on MS55 |
|---------------------------------------------------------|-----------------------|----------------------------------|-----------------------|
| 0 to 4395/8790                                          | AB 1                  | 0 to 5000/10000                  | E 2 5 (Open 1)*       |
| 0 to 2197/4395                                          | C 1                   | 0 to 2500/5000                   | E 1 5                 |
| 0 to 1099/2197                                          | AC 1                  | 0 to 1250/2500                   | AE 1 5                |
| 0 to 549/1099                                           | BC 1                  | 0 to 625/1250                    | BE 1 5                |
| 0 to 275/549                                            | ABC 1                 | 0 to 312,5/625                   | ABE 1 5               |
| 0 to 137/275                                            | D 1                   | 0 to 156,3/312,5                 | CE 1 5                |
| 0 to a 68,7/137                                         | AD 1                  | 0 to 78,1/156,3                  | ACE 1 5               |
| 0 to 34,3/68,7                                          | BD 1                  | 0 to 39,1/78,1                   | BCE 1 5               |
| 0 to 17,2/34,3                                          | ABD 1                 | 0 to 19,5/39,1                   | ABCE 1 5              |
| 0 to 8,58/17,2                                          | CD 1                  | 0 to 9,77/19,5                   | DE 1 5                |
| 0 to 4,29/8,58                                          | ACD 1                 | 0 to 4,88/9,77                   | ADE 1 5               |
| 0 to 2,15/4,29                                          | BCD 1                 | 0 to 2,44/4,88                   | BDE 1 5               |
| 0 to 1,07/2,15                                          | ABCD 1                |                                  |                       |
| Pulse width : 50 % of full cycle, with jumper 5 closed. |                       | Pulse width : 50 % of full cycle |                       |
| Pulse width : 100 msec. with jumper 5 open              |                       | * = variable width pulse         |                       |

### Readjustment procedure

Example for a CCT-55V model, with an input 0/100Vdc. For other range or for the CCT-55I model, the procedure is the same but select the correct jumpers.

- 1.- Open the housing to access the instrument internal circuits
- 2.- In ME module close A and C. In MP all jumpers open. In MS55 close E (ABCD open), solder jumper 1 and 5 closed (2 open)
- 3.- Connect voltmeter to J4 on MS55 (full scale 10Vdc)
- 4.- Generate 0Vdc to the input and operate potentiometer P1 (en ME), until the voltmeter indicates 0 Vdc
- 5.- Generate 100V to the input and operate potentiometer P2 (en ME), until the voltmeter indicates 10 Vdc
- 6.- Repeat steps 4 and 5 to correct deviations
- 7.- Connect frequency meter on terminals 11 and 12. The indication is between 2500 and 5000 Hz (depends on P3 position)
- 8.- Select on MS55 the appropriate jumpers to the desired frequency range
- 9.- Generate 100V and adjust with potentiometer P3 (en MS55), until the instrument indicates the desired frequency.

### Mechanical dimensions mm (inch)

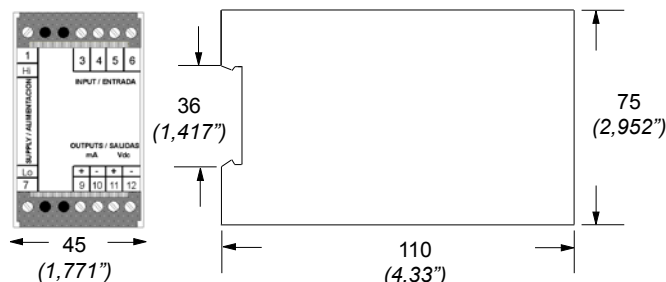

### Input signal module (ME)

Placed on the «ME» module are the potentiometers and jumpers for Zero and Gain adjustment.

- Jumper 1 .- Closed for Gross Positive Offset
- Jumper 2 .- Closed for Gross Negative Offset
- Jumper A .- Closed for Fine Negative Offset

- Jumper B .- Closed for Maximum GAIN
- Jumper C .- Closed for Middle GAIN
- Jumper B and C .- Open for Minimum GAIN

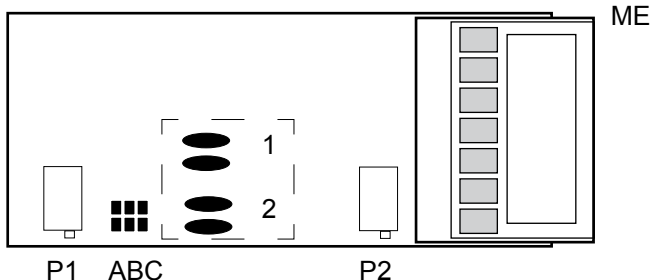

- P1 .- Zero Adjust Potentiometer
- P2 .- Gain Adjust Potentiometer

### CE Declaration of conformity

Manufacturer FEMA ELECTRÓNICA, S.A.  
 Altimira 14 - Pol. Ind. Santiga  
 E08210 - Barberà del Vallès  
 BARCELONA - SPAIN  
 www.fema.es - info@fema.es

Series CCT, models 01, 04, 06, 08, 20, 22, 23, 24, 25, 26, 27, 32, 55I, 55V, 80, 90, 95

The manufacturer declares that the instruments indicated comply with the directives and rules indicated below.

Directive of electromagnetic compatibility 2004/108/CEE  
 Directive of low voltage 73/23/CEE

Security rules 61010-1  
 Emmission rules 50081-1  
 Immunity rules 50082-1

Barberà del Vallès October 2009  
 Daniel Juncà - Quality Manager